

# FUEL LEVEL SENSOR USER MANUAL



# 1. OVERVIEW

The fuel level sensor is installed above the tank to detect the fuel level of the tank and output the mechanical pointer fuel quantity indication and voltage analog quantity.

When the liquid level changes, the float rises or falls accordingly, and is transmitted to the pointer through a curved rod motion mechanism, outputting a mechanical pointer oil quantity indicator proportional to the oil level; In addition, the motion of the linkage mechanism is simultaneously transmitted to the position sensor, outputting a voltage analog quantity of 0.5-4.5V, which is proportional to the oil level.

# 2. TECHNICAL PARAMETERS

- Working Voltage: 5V/12V/24V optional
- Power Current: ≤20mA
- Working Temperature: - 40°C ~ 85°C
- Swing Rod Motion Angle: 0°-90°
- Output Voltage: 0.5V-4.5V
- Measurement Accuracy: 1%FS
- Dial: 0-10
- Protection level: IP65

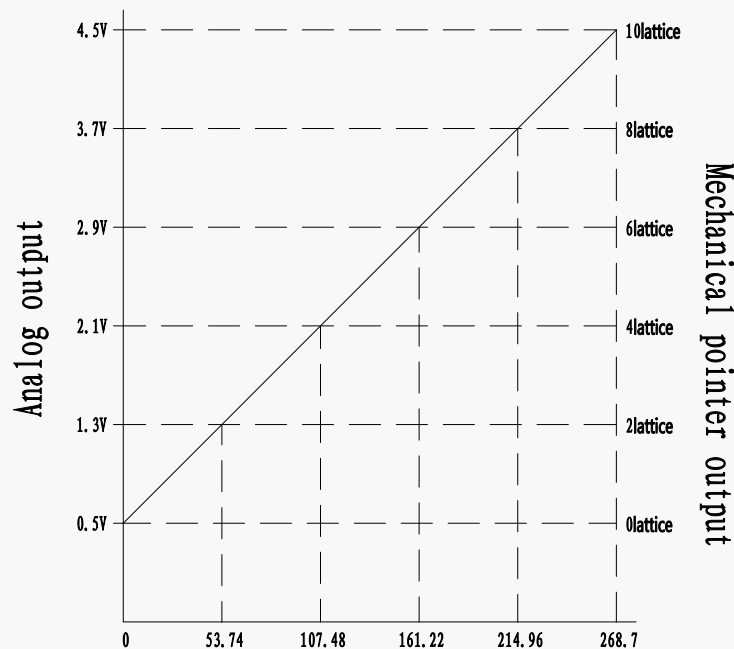

Fig. 1 Output Characteristics

### 3. WORKING PRINCIPLE

The fuel level sensor converts the linear movement of the float into the circular motion of the pointer through the curved rod movement mechanism by the float following the change of the fuel level, and at the same time transmits the position information of the rotating shaft to the position measurement electronic components. After the circuit conversion, the output is 0.5V-4.5V.

When the liquid level in the fuel tank changes from low to high, the sensor's curved rod movement mechanism rotates through a 90 ° angle. Due to the fixed length of the swing rod, the displacement of the float from low to high can be calculated, as well as the corresponding relationship between the mechanical pointer indication value and voltage analog value and the fuel level.

### 4. OVERALL DIMENSION AND INSTALLATION

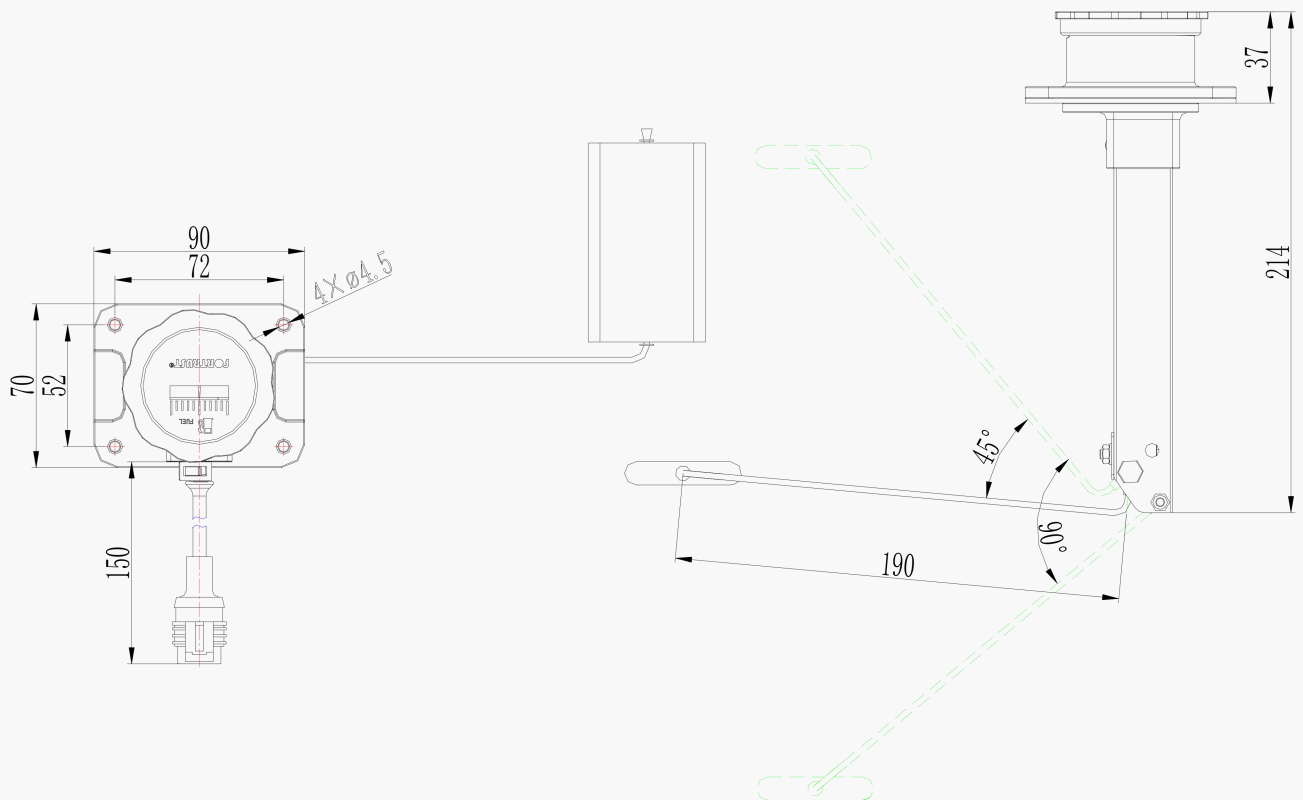

Fig. 2 Overall Dimension

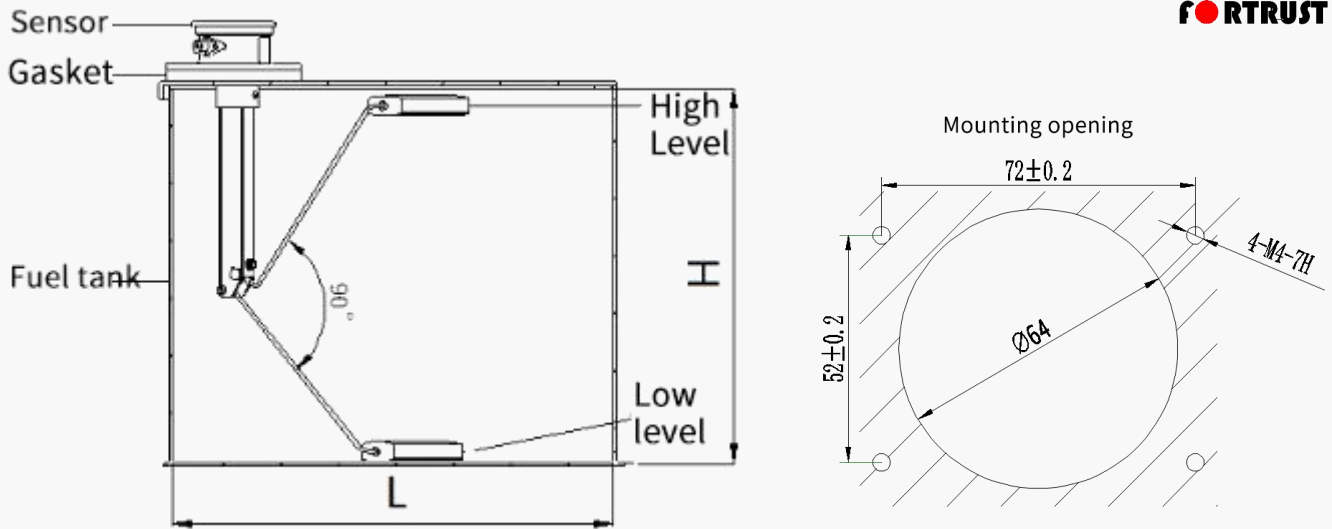

Fig.3 Installation

## 5. MODEL DESCRIPTION

Model	Applicable Height (Excluding top and bottom covers)	Working Voltage
CYOW-300-5V	300mm	5V
CYOW-300-12V	300mm	12V
CYOW-300-24V	300mm	24V
CYOW-150-5V	150mm	5V
CYOW-150-12V	150mm	12V
CYOW-150-24V	150mm	24V

**NOTE:** The measurement stroke matches the height of the fuel tank relatively, and the stroke can be customized according to the customer's model.

## 6. PIN DEFINITION

Number	Function definition	Remarks
1	V+	Red
2	GND	Black
3	Out put	Blue

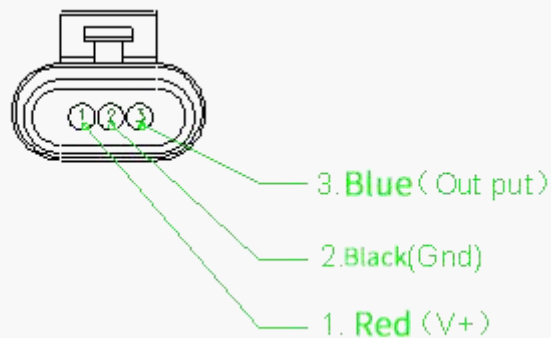

Fig. 4 Sensor Pin Definition

## 7. NOTES

- The working power supply of the fuel level sensor in the fuel tank is not allowed to be connected to the battery, and should be connected to the output of the isolated and stabilized power supply.
- The output wire of the sensor needs to be strictly wired according to the wiring definition in the user manual, ensuring accuracy and no short circuit or open circuit phenomena.
- Before installing the sensor, check whether the swing rod movement is smooth and free of jamming. Use M4 bolts to tighten it to the fuel tank flange.
- After installing the sensor into the fuel tank, check the overall sealing performance.

**FORTRUST<sup>®</sup>**

**Address: Room 803, Building A, Senlan Meilun Building, 555 Lansong Road, Pudong New District,  
Shanghai**

**Sales Hotline: 19851351321**

**Postcode: 200137**

**Factory Address: No.49 Mingzhu Road, High-Tech Industrial Development Zone, Qidong,  
Nantong, Jiangsu Province**

**Sales Hotline: 19851351386**

**Postcode: 226236**

**Web: [www.fortrustpower.com](http://www.fortrustpower.com)**

**Email: [info@fortrust.cn](mailto:info@fortrust.cn)**

